



**STRENX, HARDOX AND DOCOL
- BENDING OF HIGH STRENGTH STEEL**

SSAB

This brochure deals with bending of high strength steel for the trademarks Strenx, Hardox and Docol. The content is intended as a guide, and contains general suggestions for how to achieve the best results in bending.

Bending high strength steel sheet and plate rarely proves to be difficult, however, there are certain parameters that must be considered, which are dealt with in this brochure.

A material of high purity with few inclusions is of fundamental importance, in order to achieve a good bending result. SSAB's modern processing allows for high standards of surface quality, tolerances and mechanical properties.

PREPARATION BEFORE BENDING

- Check the rolling direction of the plate. If possible, orient the rolling direction perpendicular to the bend line. The plate can often be bent tighter this way, than with the bend line parallel to the rolling direction, figure 1.
- Check the surface quality of the plate. Surface damage can worsen bendability as it can be the cause of fractures. For heavy plates, defects on the plate such as scratches and rust can often be removed with careful grinding. Grinding scratches shall preferably be placed perpendicular to the bend line.
- Thermal cut and sheared edges should be deburred and rounded with a grinder.
- Check the condition of the tools.
- To avoid excessive tool wear, tooling should be harder than the work piece.
- Check that the tools and tool setup are in line with the given recommendations in this brochure.

FIGURE 1 Bending at right angle to the direction of rolling.

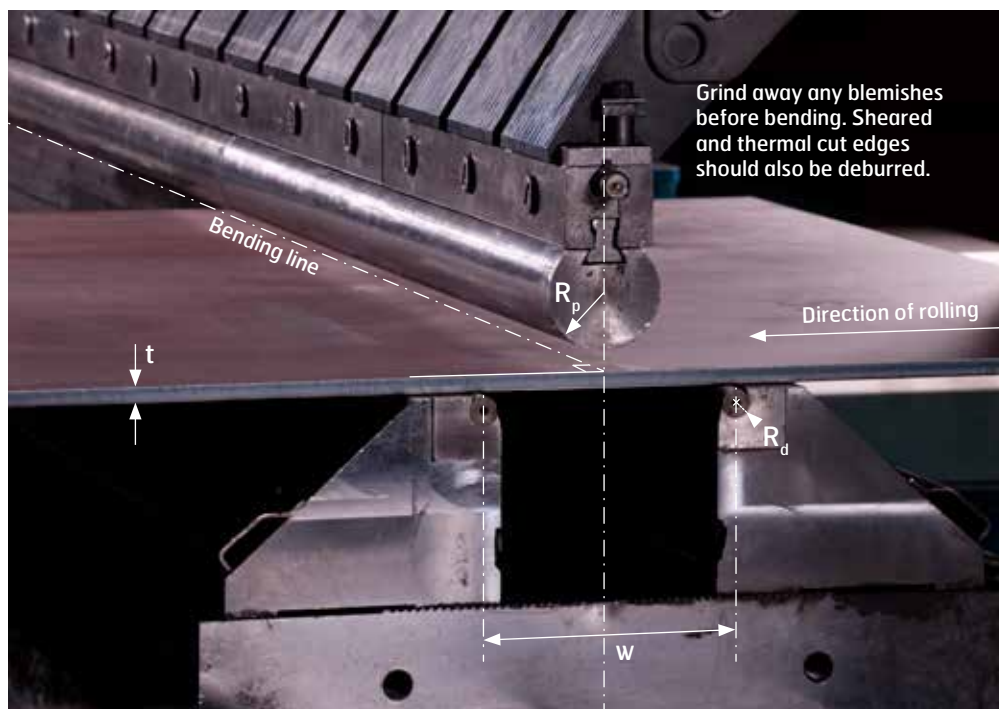

The edges of the die opening should always be as hard as, or harder than the plate being bent, in order to avoid excessive damage to the die.

A simple way of achieving this is to mill grooves in the die edges and fit lubricated round rods of, for example, hardened steel into the grooves.

The edge radius of the die should be at least half the plate thickness.

TO CONSIDER

- Pay attention to safety and follow the local safety directions. Only qualified people may be by or in the vicinity of the machine. When high strength steel is being bent, nobody should stand in front of the press brake.
- Check that the punch together with the workpiece do not bottom out in the die.
- Consider springback. Avoid rebending to correct the profile angle. The exposure of a material to previous forming processes reduces its bendability to a great extent.
- Bending force, springback and, in general, minimum recommended punch radius increase with the strength of the steel.
- In many cases for Strenx and Hardox plate products, the indentity of the plate is stamped perpendicular to the rolling direction. Avoid placing the plate so that the stamping occurs in the bend line, due to the risk of cracking
- Excessive blast cleaning can have a negative effect on bendability. Recommendations for Strenx and Hardox plate products are based upon tests with blast cleaned and painted surfaces. The recommendations for Strenx strip product and Docol are based on tests without a blasted surface.
- High strain rate may cause local a temperature increase in the bend. This could have an adverse impact on the bendability, especially for thicknesses above 20 mm. If possible, reduce the punch speed, in order to decrease the temperature difference within the work piece.

FIGURE 2 Bend.

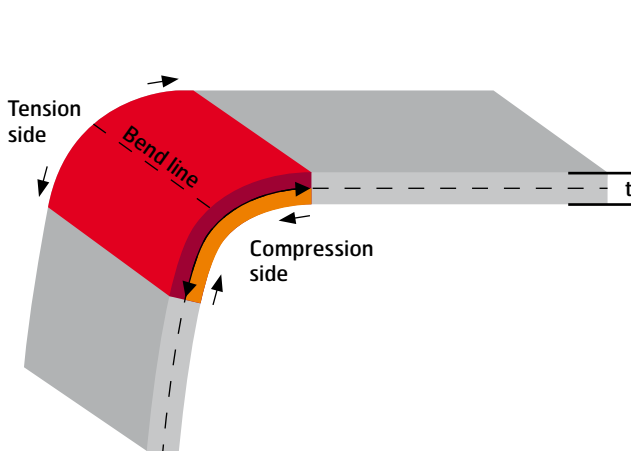

TOOLS

DIE WIDTH

Springback increases with increased die width, while punch force is reduced. Make sure that the opening angle of the die allows for over-bending, without bottoming out, to compensate for springback. An increased die opening width can in many cases lower the strain level in the bend. Also, make sure that there is enough room for the chosen punch together with the workpiece, in the die, during bending, without deforming the die. The minimum recommended die opening width are shown in tables 2 and 3.

The die edge radius should be at least half the plate thickness. Alternatively, the die width should be increased in order to minimize pressure on the die edge radius, and consequently reduce the risk of die marks.

PUNCH

The suitable punch radius, along with the die width, is the most important parameter. When bending high strength steel, the final inner radius often becomes somewhat smaller than the radius of the punch, figure 3. When there is low friction between plate and tools, the phenomenon becomes more obvious.

For steel with yield strength over approximately 500 MPa, a punch radius of the same size or slightly larger than the desired bending radius is recommended. Tables 2 and 3 on page 7 show the minimum recommended punch radius when bending to 90°.

FIGURE 3 Separation of the plate and punch.

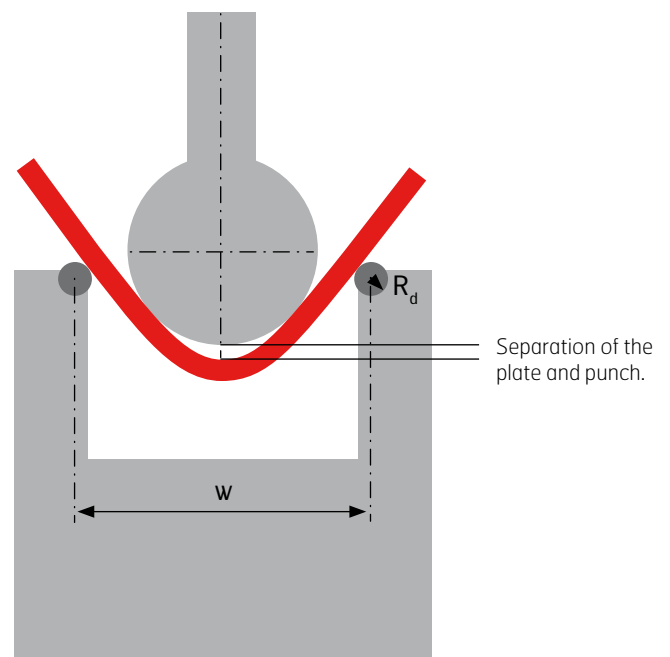

CONDITION OF TOOLS

Due to the increased contact pressure between plate and tools when bending high strength steel, wear on the tools increases somewhat. Check at regular intervals, that the punch radius and die edge radius are both constant. For bends that have cracked in a construction, the crack has in many cases propagated from the compression side of the bend, figure 2. This can often be attributed to poor condition of the punch. The edges of the die should remain clean and undamaged.

MACHINE STABILITY

Required punch force is often high when bending high strength steel. The static friction coefficient is typically higher than the kinetic. This can cause the plate to lock over the edge of one die edge radius, and at the same time, slide over the other one. In this way, the workpiece swings down into the die in a discontinuous way during the bending process. This phenomenon, called stick-slip, can result in higher strains over the bend. Use a stable machine and steady tool fastening. Lubrication of the die edge or use of a rotating die edge radius can be helpful, avoiding stick-slip and also lowering the punch force.

CROWNING

Crowning compensates for the elastic deflection of the bending machine under load, figure 4. The central part of punch and die deflects the most. By crowning, the deflection (C) can be compensated for, thus achieving the same bending angle along the entire blank length. If the bend profile becomes curved along the bend line (B) this cannot be compensated for by crowning.

After unloading compressive stresses arise on the stretched side, at the same time as tensile stresses appear on the compressed side, figure 2. The stress distribution over the plate thickness causes longitudinal stresses. It is those stresses that tend to curve the profile. The magnitude of curvature depends mainly on the flange height and the profile stiffness.

Additional considerations have to be made when setting the crowning at stepwise bending of long profiles.

FIGURE 4 Crowning.

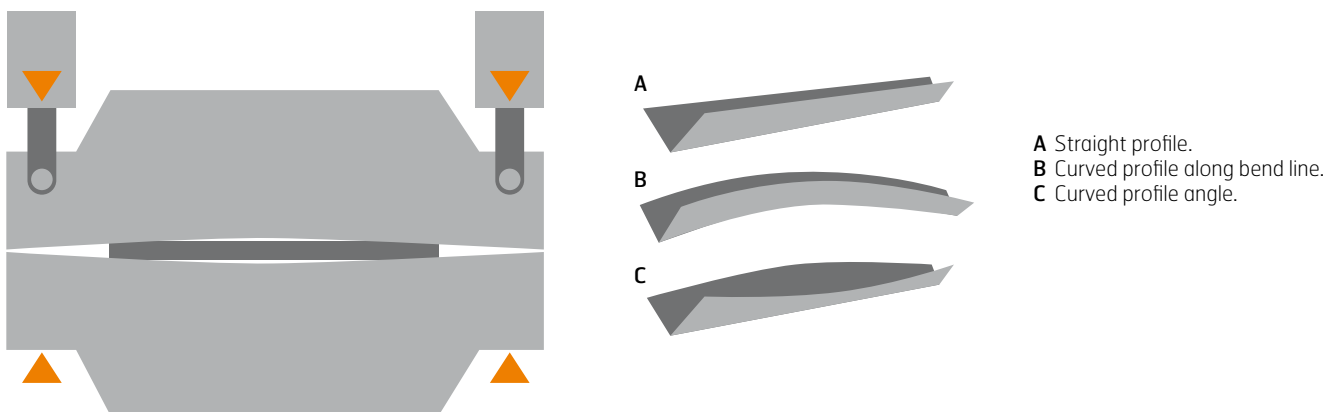

BENDING FORCE

To make an estimation of the force needed during bending, we pay attention not only to the bend length, plate thickness, die width and tensile strength, but also the changing moment arm during bending. The peak load is assumed to be reached at a bend opening angle of 120° with normal friction (no lubrication). Trial tests are always recommended.

$$P = \frac{b \cdot t^2 \cdot R_m}{(W - R_d - R_p) \cdot 9\,800}$$

P = Bend force, tons (metric)
 t = Plate thickness, mm
 W = Die width, mm (figure 1)
 b = Bend length, mm
 R_m = Tensile strength, MPa (table 1)
 R_d = Die entry radius, mm
 R_p = Punch radius, mm

The SSAB Bending Formula® is verified by tests for 90° bends, see figure 5.

TABLE 1 Typical tensile strength values to calculate bend force.

TYPE OF STEEL	TYPICAL TENSILE STRENGTH (MPa)
S355	550
Strenx 600 MC	760
Strenx 650 MC	800
Strenx 700, 700 MC, 700 PLUS	860, 850, 840
Strenx 900, 900 MC, 900 PLUS	1010, 1150, 1060
Strenx 960, 960 MC, 960 PLUS	1060, 1200, 1120
Strenx 1100, 1100 MC	1440, 1320
Strenx 1300	1530
Docol 600 DP/DL	660
Docol 800 DP/DL	860
Docol 1000 DP	1090
Docol 1200 M	1300
Docol 1300 M	1400
Docol 1400 M	1510
Docol 1500 M	1600
Hardox 400	1250
Hardox 450	1400
Hardox 500	1650

EXAMPLE 1

A certain press brake is just capable of bending a 20 mm thick EN10025 – S355 steel plate in a die with a 200 mm wide opening, and die entry radius of 15 mm. The punch radius is 40 mm.

If the same die and punch is used and the bend length is the same, how thick a Hardox 400 plate is the press brake capable to bend?

The bending forces should be same, and only the plate thickness (t) and tensile strength (R_m) will differ. Substituting in the above formula and simplifying: 20² x 550 = t² x 1250

The thickness (t) of the Hardox plate will be 13.3 mm. The R/t ratio will then be 40/13.3 = 3.0. According to table 2, the Hardox 400 plate can be bent transverse rolling direction with this punch radius. The W/t ratio for Hardox 400 plate will be 200/13.3 = 15.0 which, according to table 2, is satisfactory.

EXAMPLE 2

A 2000 mm long bracket is to be produced by bending plate. The choice lies between using:

a) 10 mm thick plate of EN10025 – S355 with a typical tensile strength of 550 MPa,

or

b) 7 mm thick plate of Strenx 700 with a typical tensile strength of 860 MPa.

In both cases, an existing die with a 100 mm wide opening and die entry radius of 10 mm, is to be used. The punch radius is 14 mm in both cases. What press force will be needed for each steel grade?

$$\text{For S355 } P = \frac{2000 \cdot 10 \cdot 10 \cdot 550}{(100 - 10 - 14) \cdot 9\,800} = 148 \text{ ton}$$

$$\text{For Strenx 700 } P = \frac{2000 \cdot 7 \cdot 7 \cdot 860}{(100 - 10 - 14) \cdot 9\,800} = 113 \text{ ton}$$

Since the plate thickness has a greater influence than the strength, the force needed for bending Strenx-plate in this particular case is lower.

FIGURE 5 Bending force

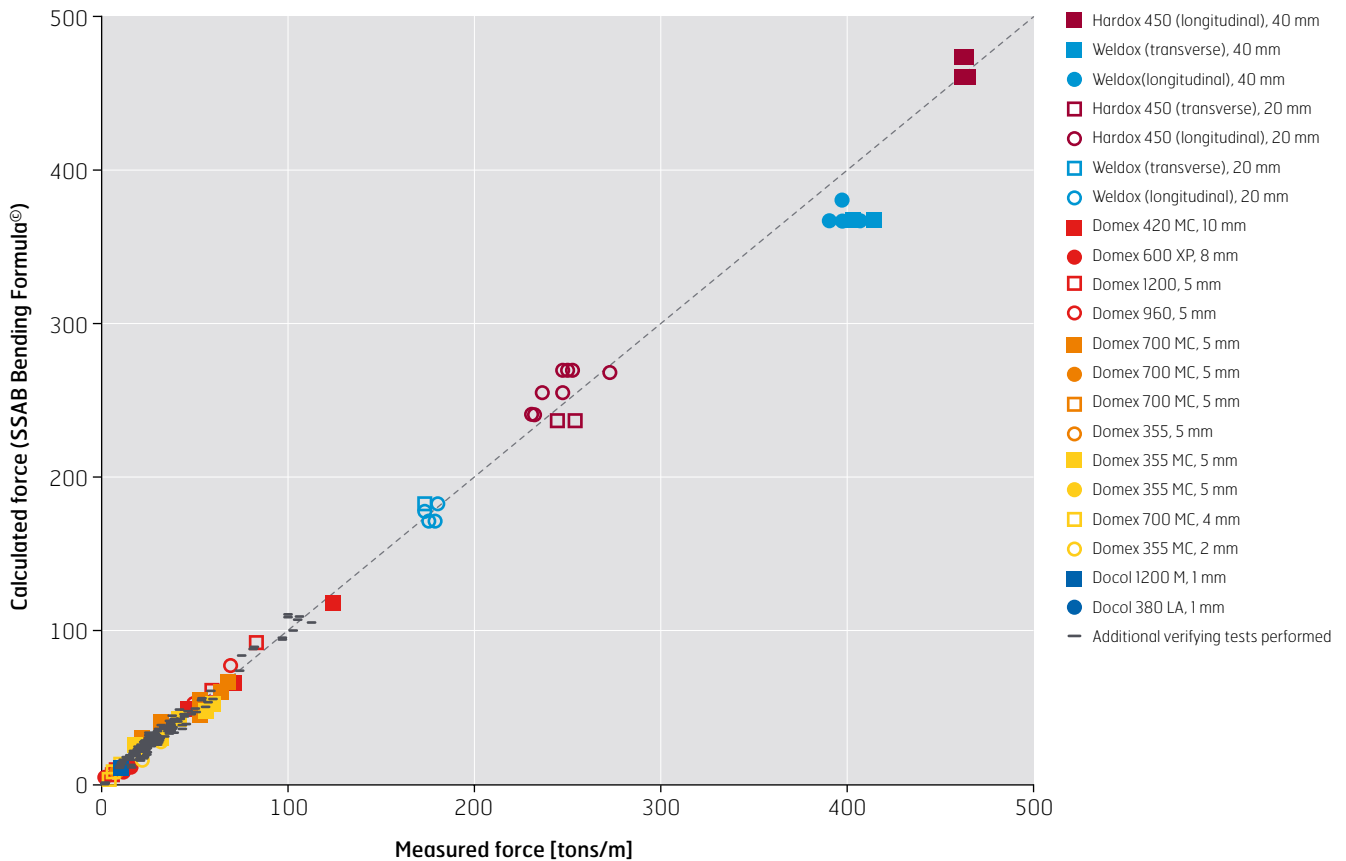

The SSAB Bending Formula[®] is verified by tests performed within a wide range of thicknesses and grades, the specimens are bent to 90°. Tooling setups are in line with SSAB's bend recommendation.

SPRINGBACK

Springback increases with steel strength and the ratio between die width and plate thickness (W/t). Material yield strength has the biggest influence.

When bending, a varying residual stress distribution is achieved over the bend cross section. The plastic strain level and the distribution of these stresses will control the tendency for springback. All springback is fully elastic.

To compensate for springback, the die should be shaped in such a way to allow overbending without coining the material.

It is very difficult to accurately predict the springback of a material when bending, since this depends to a large extent on each unique tool setup. That is why trials are recommended. For thinner plate or sheet ($t < 10$ mm), an estimation of the material's springback, in degrees, can be achieved by dividing the tensile strength (MPa) by 100.

A precondition is that the die width is approximately 10–12 x the plate thickness.

PARAMETERS THAT AFFECT SPRINGBACK:

- Yield strength of the material – higher yield strength causes greater springback.
- Punch radius – increased punch radius will cause greater springback.
- Die width – larger die width causes greater springback.
- The strain hardening of the material.

BENDING RECOMMENDATIONS

Since SSAB's products are developed and specialized for different types of use, bend tests and evaluation of these vary somewhat.

For plate products the minimum recommended relationship between the punch radius and plate/sheet thickness (R/t) is shown in table 3.

For Strenx strip products and Docol, the relationship between minimum inner radius and sheet thickness (R_i/t) is shown in table 2.

These bend recommendations are based on bend tests of one step to 90° after unloading. Die opening width are guidelines and may vary somewhat without affecting bending results.

Tables 2 and 3 shows a small selection from SSAB's product range. For information about other materials and more technical information, please contact Tech Support or visit www.ssab.com.

Strenx and Hardox is delivered with guaranteed bending performance according to Strenx and Hardox guarantee. For more information contact your local SSAB representative.

TABLE 2 The bending recommendations for Strenx strip products and Docol are based on fixed die edges and normal friction (no lubrication). R_i/t applies for all bend directions. R_i/t stands for inner radius on the sheet (R_i) divided by sheet thickness (t).

		THICKNESS (t) (mm)	ALONG ROLLING DIRECTION MINIMUM R_i/t	DIE OPENING WIDTH (W) MINIMUM W/t
HOT ROLLED STRIP	Strenx 600 MC	$t \leq 3$	0.7	10
		$3 < t \leq 6$	1.1	10
		$t > 6$	1.4	10
	Strenx 650 MC	$t \leq 3$	0.8	10
		$3 < t \leq 6$	1.2	10
		$t > 6$	1.5	10
	Strenx 700 MC	$t \leq 3$	0.8	10
		$3 < t \leq 6$	1.2	10
		$t > 6$	1.6	10
	Strenx 700 MC PLUS	$3 \leq t \leq 10$	1.0	10
$t > 10$		1.5	10	
Strenx 900 MC	$3 \leq t \leq 8$	3.0	12	
	$t > 8$	3.5	12	
Strenx 900 PLUS	$3 \leq t \leq 6$	3.0	12	
Strenx 960 MC	$3 \leq t \leq 10$	3.5	12	
Strenx 960 PLUS	$3 \leq t \leq 6$	3.5	12	
Strenx 1100 MC	$3 \leq t \leq 8$	4.0	14	
COLD ROLLED STRIP	Docol 600 DP/DL	$0.5 \leq t \leq 2.1$	0.5	10
	Docol 800 DP/DL	$0.5 \leq t \leq 2.1$	1.0	10
	Docol 1000 DP	$0.5 \leq t \leq 2.1$	2.0	10
	Docol 1200 M	$0.5 \leq t \leq 2.1$	3.5	12
	Docol 1300 M	$0.5 \leq t \leq 2.1$	3.5	14
	Docol 1400 M	$0.5 \leq t \leq 2.1$	4.0	14
Docol 1500 M	$0.5 \leq t \leq 2.1$	4.0	14	

TABLE 3 The bending recommendations for Strenx plate products and Hardox are based on dies with rolls and normal friction (no lubrication). R/t stands for punch radius (R) divided by sheet thickness (t).

		THICKNESS (t) (mm)	TRANSVERSE TO ROLLING DIRECTION MINIMUM R/t	ALONG ROLLING DIRECTION MINIMUM R/t	DIE OPENING WIDTH (W) MINIMUM W/t
HOT ROLLED PLATE	Strenx 700	$t < 8$	1.5	2.0	10
		$8 \leq t < 15$	1.5	2.0	10
		$15 \leq t < 20$	2.0	2.5	12
		$t \leq 20$	2.0	2.5	12
	Strenx 900/960	$t < 8$	2.5	3.0	12
		$8 \leq t < 15$	2.5	3.0	14
		$15 \leq t < 20$	2.5	3.0	14
		$t \leq 20$	3.0	3.5	16
	Strenx 1100	$t < 8$	3.0	3.5	12
		$8 \leq t < 15$	3.0	3.5	14
		$15 \leq t < 20$	3.0	3.5	14
		$t \leq 20$	3.5	4.0	16
	Strenx 1300	$t < 8$	3.5	4.0	14
		$8 \leq t < 15$	4.0	4.5	14
	Hardox 400	$t < 8$	2.5	3.0	12
		$8 \leq t < 15$	3.0	4.0	14
$15 \leq t < 20$		3.0	4.0	14	
$20 \leq t < 50$		4.0	5.0	16	
Hardox 450	$t < 8$	3.0	3.5	12	
	$8 \leq t < 15$	3.5	4.5	14	
	$15 \leq t < 20$	3.5	4.5	14	
	$t \leq 20$	4.5	5.0	16	
Hardox 500	$t < 8$	3.5	4.5	14	
	$8 \leq t < 15$	4.0	4.5	14	
	$15 \leq t < 20$	4.5	5.0	16	
	$t \leq 20$	5.5	6.0	18	
HOT ROLLED STRIP	Hardox 400	$2 \leq t < 4$	3.0	4.0	12
		$4 \leq t \leq 8$	3.0	3.5	12
	Hardox 450	$2.5 \leq t < 4$	3.0	4.0	12
$4 \leq t \leq 8$		3.0	3.5	12	
Hardox 500	$3 \leq t \leq 6.5$	3.5	4.0	14	

SSAB is a Nordic and US-based steel company. SSAB offers value added products and services developed in close cooperation with its customers to create a stronger, lighter and more sustainable world. SSAB has employees in over 50 countries. SSAB has production facilities in Sweden, Finland and the US. SSAB is listed on the NASDAQ OMX Nordic Exchange in Stockholm and has a secondary listing on the NASDAQ OMX in Helsinki. www.ssab.com

SSAB
SE-613 80 Oxelösund
Sweden

T +46 155 25 40 00
F +46 155 25 40 73
contact@ssab.com

www.ssab.com

SSAB
SE-781 84 Borlänge
Sweden

T +46 243 700 00
F +46 243 720 00
contact@ssab.com

SSAB